

# CENTURY<sup>®</sup> 9055

3-Stage Boom and other optional equipment shown.

## BUILT TO PERFORM.

The 9055 is Century's largest capacity integrated towing and recovery unit. Dual 50,000 lb. planetary winches mounted on a full hydraulic 50-ton recovery boom combined with an integrated underlift that offers full power tilt sets the 9055 well ahead of the competition. Couple those features with an underlift reach of 136", an underlift design that does not interfere with recovery applications plus a weight conscious body design, and you'll understand why the 9055 from Century is in a class by itself.

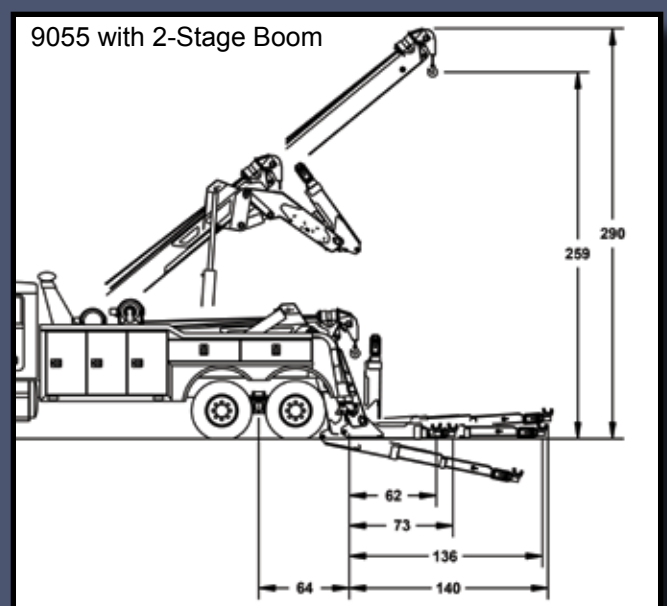
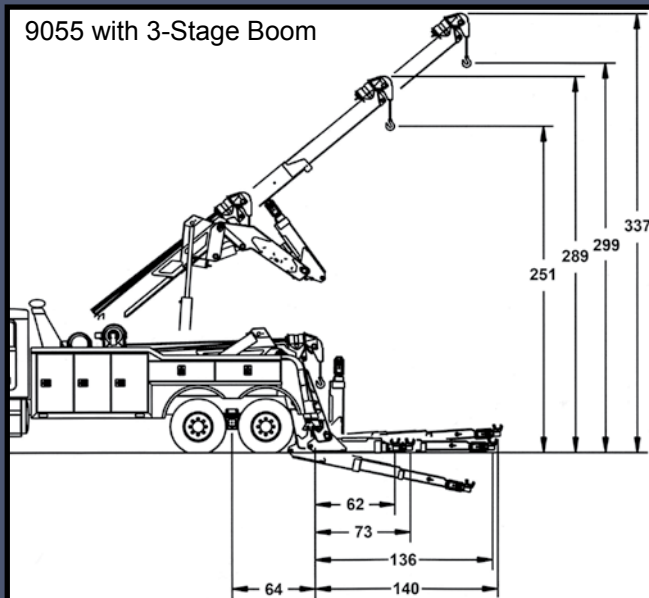



# CENTURY 9055

## BODY

Standard Body Configuration  
156" Aluminum  
Optional Body Configurations  
180" Aluminum  
204" Aluminum  
SP 850-XP

## BOOM

Boom Structural Rating  
- Retracted 30° ..... 100,000 lbs.  
- Extended 30° (2-Stage) ..... 30,000 lbs.  
- Extended 30° (3-Stage) ..... 18,000 lbs.  
Maximum Extension (2-Stage) ..... 140"  
Maximum Extension (3-Stage) ..... 216"  
Maximum Angle ..... 39°  
Maximum Hook Height (2-Stage) ..... 259"  
Maximum Hook Height (3-Stage) ..... 299"  
Reach Past Tailboard 3° Boom Angle (2-Stage) ..... 127"  
Reach Past Tailboard 3° Boom Angle (3-Stage) ..... 199"  
Lift Cylinder Size ..... 7" Bore  
\*Estimated Shipping Weight (2-Stage) ..... 17,650 lbs.  
\*Estimated Shipping Weight (3-Stage) ..... 18,200 lbs.

## WINCH

Winch Capacity ..... (2) 50,000 lbs.  
Winch Type ..... Planetary  
Cable 6 x 37 I.W.R.C. .... 3/4" x 250'

## UNDERLIFT

Underlift Tilt ..... +10° / -7°  
Capacity Fully Extended to C.L. of Forks ..... 17,000 lbs. @ 136"  
Capacity Fully Retracted to C.L. of Forks ..... 55,000 lbs. @ 62"

## RECOMMENDED MINIMUM CHASSIS

Front Axle ..... 14,600 lbs.  
Rear Axle ..... 40,000 lbs.  
Clear C.B. .... 156" C.B.  
After Frame from Center of Rear Axle ..... 40"  
R.B.M ..... 3,000,000 in/lb.

All recommendations are minimums, heavier specifications may be required depending on chassis and equipment weight, always consult your local distributor or the factory for additional information. The outside frame rails of chassis extending behind cab must be free of fuel tanks, air tanks, battery boxes, etc.

All ratings are based on structural factors only, not vehicle capacities or capabilities. Specifications shown are approximations and may vary depending on chassis selected. Miller Industries Towing Equipment Inc. reserves the right to change or modify product and/or specifications without notice or obligation. Some optional equipment shown.

## STANDARD BODY FEATURES

- Aluminum Modular Body
- 96" Wide
- 3 Large Forward Compartments
- Compartments Over the Wheel Well
- Double Panel Doors
- Door Checks
- Double Action Latches w/ Key
- Federal #108 Lighting
- Flexible Wire Loom
- Toolbox Lights
- Rubber Fenderettes
- Mud Flaps
- Side Worklights
- Chain Rack
- Fork Holders
- Recessed Air & Electrical Hookups
- Adjustable Shelves
- Rubber Isolators
- Enclosed Inner Wheel Wells
- Light Pylon - 3 Piece
- "D" Rings (Tailboard Mount)
- Tail Board Recovery Anchors
- Diagonal Rear Spades
- Flipper Foot Spades
- Dual Hydraulic Pump
- Fork Riser Brackets
- Power Touch System  
(Includes 15-Function Wired and Wireless Controllers, In-Cab Underlift Controls, and Front & Rear 12-Function Switch Panels)

## STANDARD BOOM FEATURES

- Power Elevation
- Power Extension
- Dual Planetary Hydraulic Winches
- Cable Air Tensioners
- Air Free Spools
- 360° Sheave Head
- Cable Tie Back (Boom)
- Dual Control Stations
- Hydraulic Pressure Gauges (Drivers Side)

## STANDARD UNDERLIFT FEATURES

- Power Elevation
- Power Extension
- Power Tilt
- Hydraulic Fold
- 3-Stage Design

## STANDARD UNDERLIFT FEATURES

- 2 Piece Pivot Pin
- Upper/Lower Thrust Washer
- Handheld Lanyard
- Low Profile Crossbar
- 70° Pivoting Crossbar
- Low Profile Fork Holders
- 8 Sets of Cast Steel Forks
- 1 Pair Spring Lift Adapters
- 1 Pair Hook Adapters
- Safety Chains in Rear Pockets

## OPTIONAL EQUIPMENT

- 156" Low Rider Underlift
- Air Shift P.T.O.
- Tailgate Underlift Controls
- Additional Body Lengths
- Tunnel Crossovers
- 24", 30", 36" and 48" Tunnel Saddle Box
- LED Smart Lights
- Convenience Group
- Aluminum Dress-up Kits
- Composite Aerodynamic Light Pylon
- Composite Boom Wings
- 7-Drawer Tool Box
- Washdown Sink
- Offset Fork Holder Extensions
- Chain Hook Slide Adapter
- Pintle Hook Attachment
- 5th Wheel Plate (Requires Pintle Hook Attachment)
- King Pin Attachment (Requires Pintle Hook Attachment)
- Trailer Ball Adapter (Requires Pintle Hook Attachment)
- Heavy-Duty Tire Lift
- Tire Lift Storage Brackets
- Additional Lifting Forks
- Low Pull "D" Ring Kit
- Chain Package
- Recovery Straps
- Snatch Blocks
- Boom Angle Indicator
- Light Bar
- Strobe Kit
- Work & Hookup Lighting
- Wide Load Light Bar
- On-Board Truck Scale
- Engine Data Information Center
- Rear Camera & Monitor Installation



Optional "Low Rider" underlift provides 156" of reach.



8503 Hilltop Drive • Ooltewah, TN 37363 Distributed by:  
Phone: (423) 238-4171 • (800) 292-0330  
Fax: (423) 238-5371  
www.millerind.com