

CENTURY®

LEGENDARY LEADERSHIP



CENTURY'S 4024/T2 MEDIUM-DUTY TOWING and RECOVERY EQUIPMENT

Developed to handle a wide range of tough jobs, the Century 4024/T2 combines field-proven components into a modular, weight-saving, high-tech design that creates an unbeatable value package. These units feature an integrated boom and underlift, with power tilt for versatility ... along with many of the same features and options which were pioneered in the successful Century 5030. There's no doubt about it ... whether you're pulling a motorhome, delivery van or road tractor, the 4024/T2 should meet your towing and recovery needs.

Note: Some optional equipment may be shown. Other Century towing and recovery equipment is available from your local Century Distributor.

Century 4024/T2

Wrecker Specifications

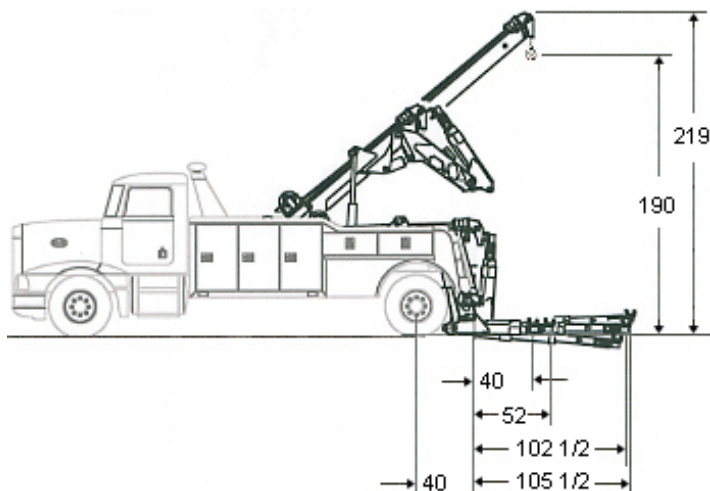

Body

Standard Body Configuration

- > 138" C.A. Aluminum

Optional Body Configuration

- > 156" C.A. Aluminum
- > 156" Heavy Duty Aluminum

Maximum frame height for the 4024/T2 is 40".

Contact the factory for information on taller frame height.

Boom

Boom Structural Rating (S.A.E.)

- > Retracted 30° 40,000 lbs.
- > Extended 30° 15,000 lbs.

Maximum Extension 96"

Maximum Angle 40°

Maximum Hook Height 190"

Reach Past Underlift 3° Boom Angle 86"

Lift Cylinder Size 5" Bore

*Estimated Shipping Weight 8875 lbs.

Winch

Winch Capacity (2) 20,000 lbs.

Winch Type Planetary

Cable Specifications

- > 9/16" x 175'
- > 6 x 19 Fiber I.P.S.

Air Cable Tensioners Standard

Air Winch Clutch Release Standard

Underlift

Underlift Tilt 8°

Capacity Fully Extended to C.L. of Forks 12,000 lbs. @ 102.5"

Capacity Fully Retracted to C.L. of Forks 24,000 lbs. @ 40"

Recommended Minimum Chassis

Front Axle 10,000

Rear Axle 21,000

Clear C.A. 138" C.A.

After Frame from Center of Rear Axle 42"

R.B.M. 1,200,000 in/lb.

All recommendations are minimums, heavier specifications may be required depending on chassis and equipment weight, always consult your local distributor or the factory for additional information. The outside frame rails of chassis extending behind cab must be free of fuel tanks, air tanks, battery boxes, etc.

Standard Body Features

- Aluminum Modular Body
- 96" Wide
- 3 Large Forward Compartments
- Compartment Over Wheel Well
- Galvanized Double Panel Doors
- Door Checks
- Double Action Latches w/Key
- Federal #108 Lighting
- Flexible Wire Loom
- Toolbox Lights
- Rubber Fenderettes
- Mud Flaps
- Side Worklights
- Chain Rack
- Fork Holders
- Recessed Air & Electrical Hookups
- Shelves
- Rubber Isolators
- Enclosed Inner Wheel Wells
- Light Pylon – 3 Piece
- Power Pal System includes 8-Function, Hand-Held Lanyard Control & 9-Function Floor Mounted Switch Panel

Standard Boom Features

- Power Elevation
- Power Extension
- Dual Planetary Hydraulic Winches
- Air Cable Tensioners
- Air Free Spools
- Diagonal Rear Spade
- Flipper Foot Spade
- Dual Hydraulic Pump
- 360° Sheave Head
- Cable Tie Back (Boom)
- Dual Control Stations
- Hydraulic Pressure Gauges (Drivers Side)
- Tail Board Recovery Anchors

Standard Underlift Features

- Power Elevation
- Power Extension
- Power Tilt
- Hydraulic Fold
- 3 Stage Design
- 2 Piece Pivot Pin
- Upper/Lower Thrust Washer
- Handheld Lanyard
- Low Profile Crossbar
- 70° Pivoting Crossbar
- Low Profile Fork Holders
- 8 Sets Cast Steel Forks

Standard Underlift Features (cont)

- 1 Pair Spring Lift Adapters
- 1 Pair Hook Adapters
- Safety Chains in Rear Pockets

Optional Equipment

- Air Shift P.T.O.
- Tailgate Underlift Controls
- Additional Body Lengths
- Tunnel Crossovers
- 24", 30", 36", and 48" Tunnel Saddle Box
- LED Smart Lights (Aluminum body)
- Convenience Group (Rails & Steps)
- Aluminum Dress-up Kits
- Composite Aerodynamic Light Pylon
- Composite Boom Wings
- 7-Drawer Tool Box
- Folding Sink
- Offset Fork Holder Extensions
- Fork Riser Brackets
- Chain Hook Slide Adapter
- Pintle Hook Attachment
- 5th Wheel Plate (Requires Pintle Hook Attachment)
- King Pin Attachment (Requires Pintle Hook Attachment)
- Trailer Ball Adapter (Requires Pintle Hook Attachment)
- Heavy-Duty Tire Lift
- Tire Lift Storage Brackets
- Additional Lifting Forks
- "D" Rings (Tail Board Mount)
- Low Pull "D" Ring Kit
- Chain Kits
- Recovery Straps
- Snatch Blocks
- Boom Angle Indicator
- Light Bar
- Strobe Kits
- Work & Hookup Lighting
- Wide Load Light Bar
- On-Board Truck Scale
- Engine Data Information Center
- Rear Camera and Monitor
- Installation
- Power Touch System includes 15-Function Wired and Wireless Controllers, In-Cab Underlift Controls, and Front & Rear 12-Function Switch Panels

All ratings are based on structural factors only, not vehicle capacities or capabilities. Specifications shown are approximations and may vary depending on chassis selected. Miller Industries Towing Equipment Inc. reserves the right to change or modify product and or specifications without notice or obligation. Some equipment shown is optional.



8503 Hilltop Drive
Ooltewah, TN 37363
PHONE (423) 238-4171
(800) 292-0330
FAX (423) 238-5371

DISTRIBUTED BY: